

鼓风机 & 空调 (手动)

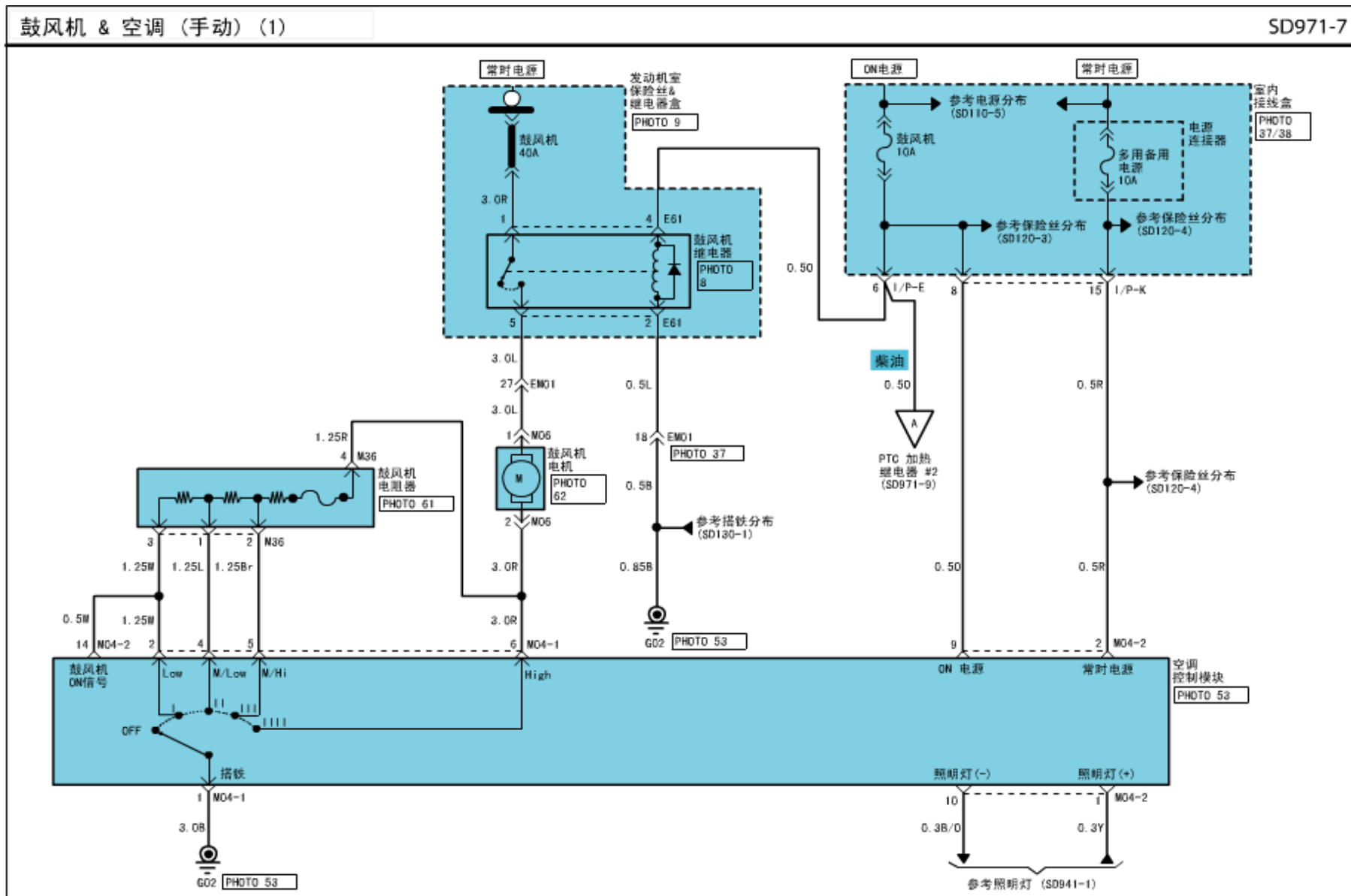



鼓风机 & 空调 (手动)

鼓风机 & 空调 (手动) (3)

SD971-9

柴油

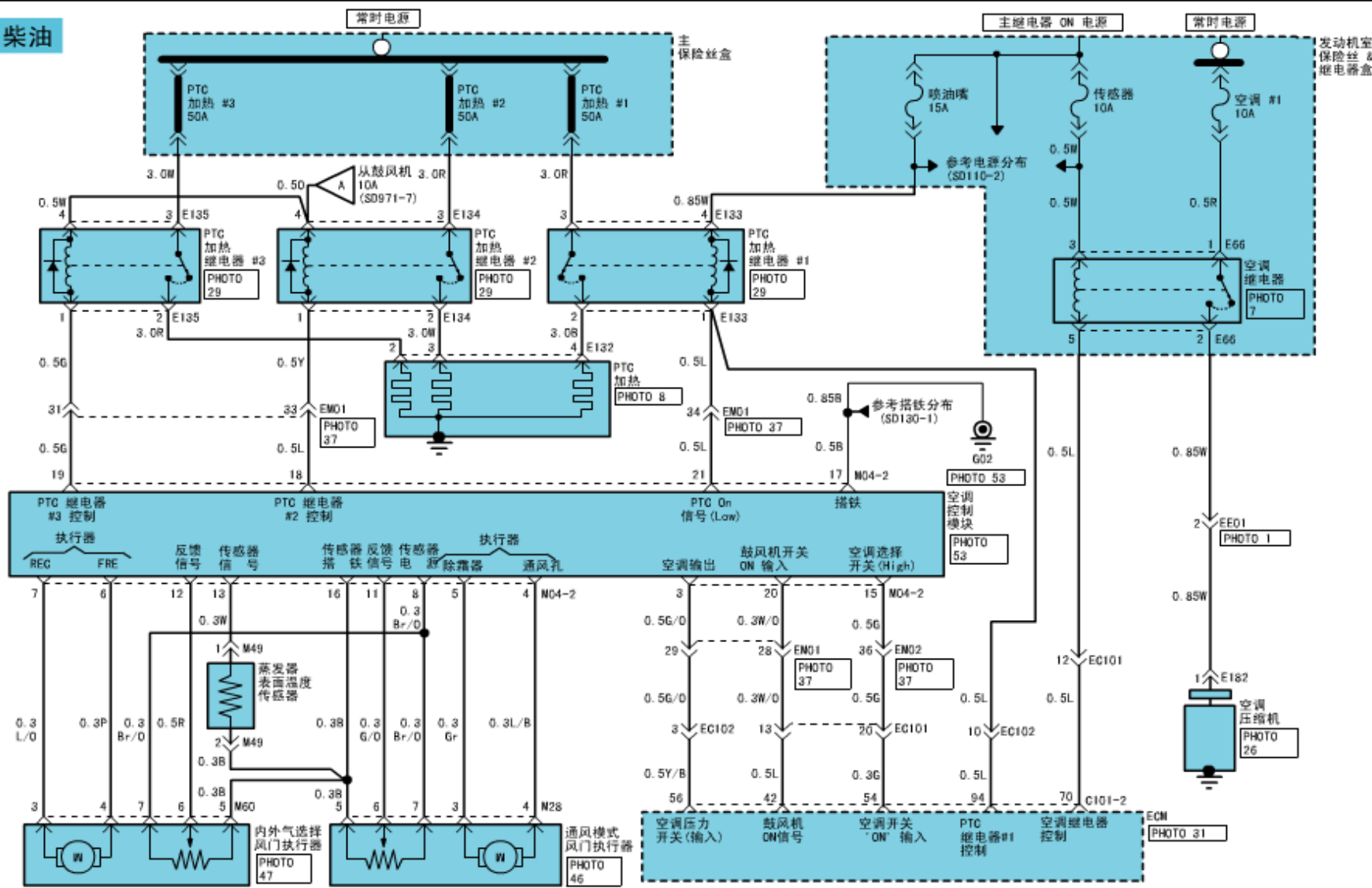

鼓风机 & 空调 (手动)

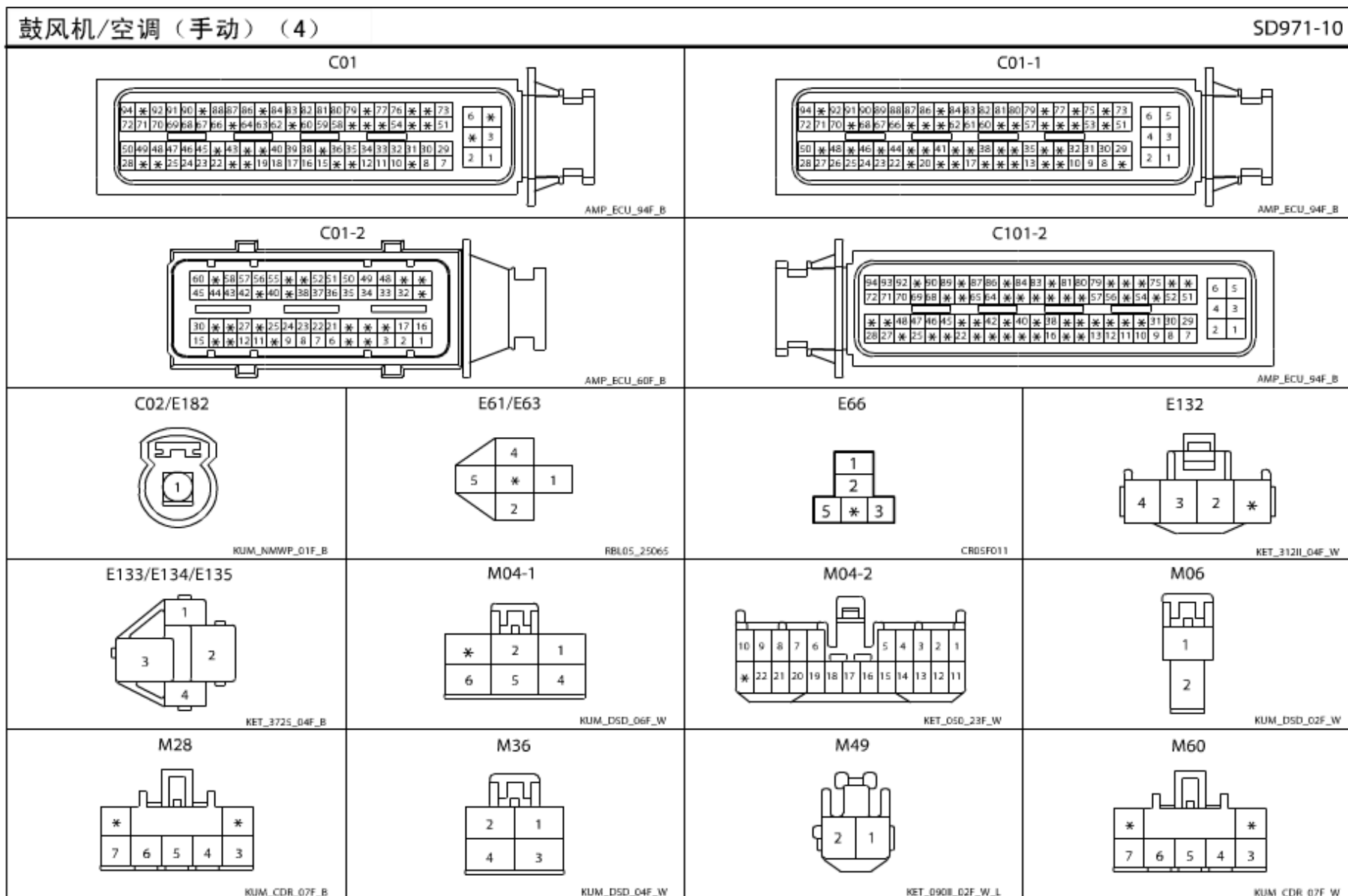

鼓风机 & 空调 (自动)

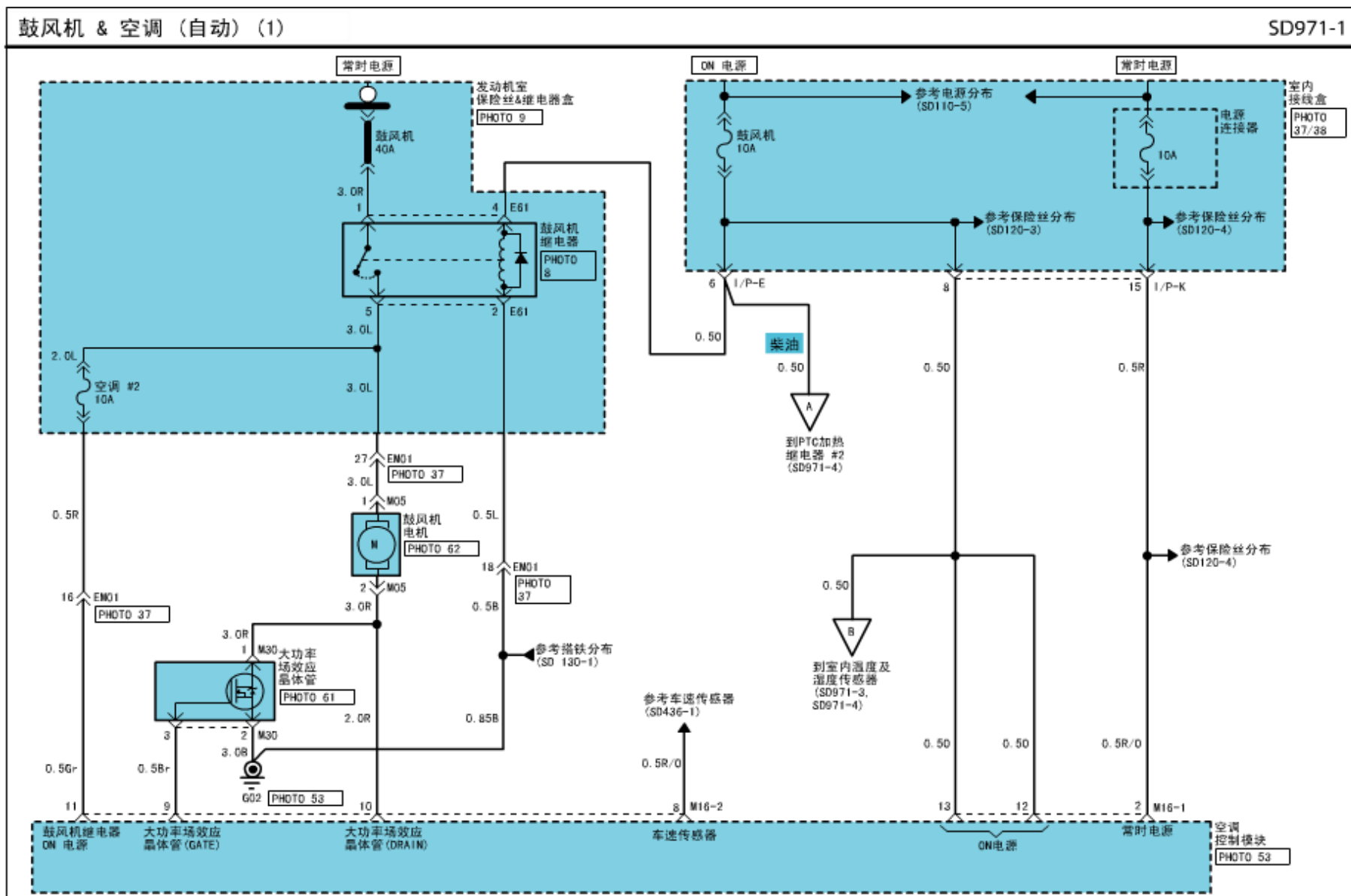

鼓风机 & 空调 (自动)

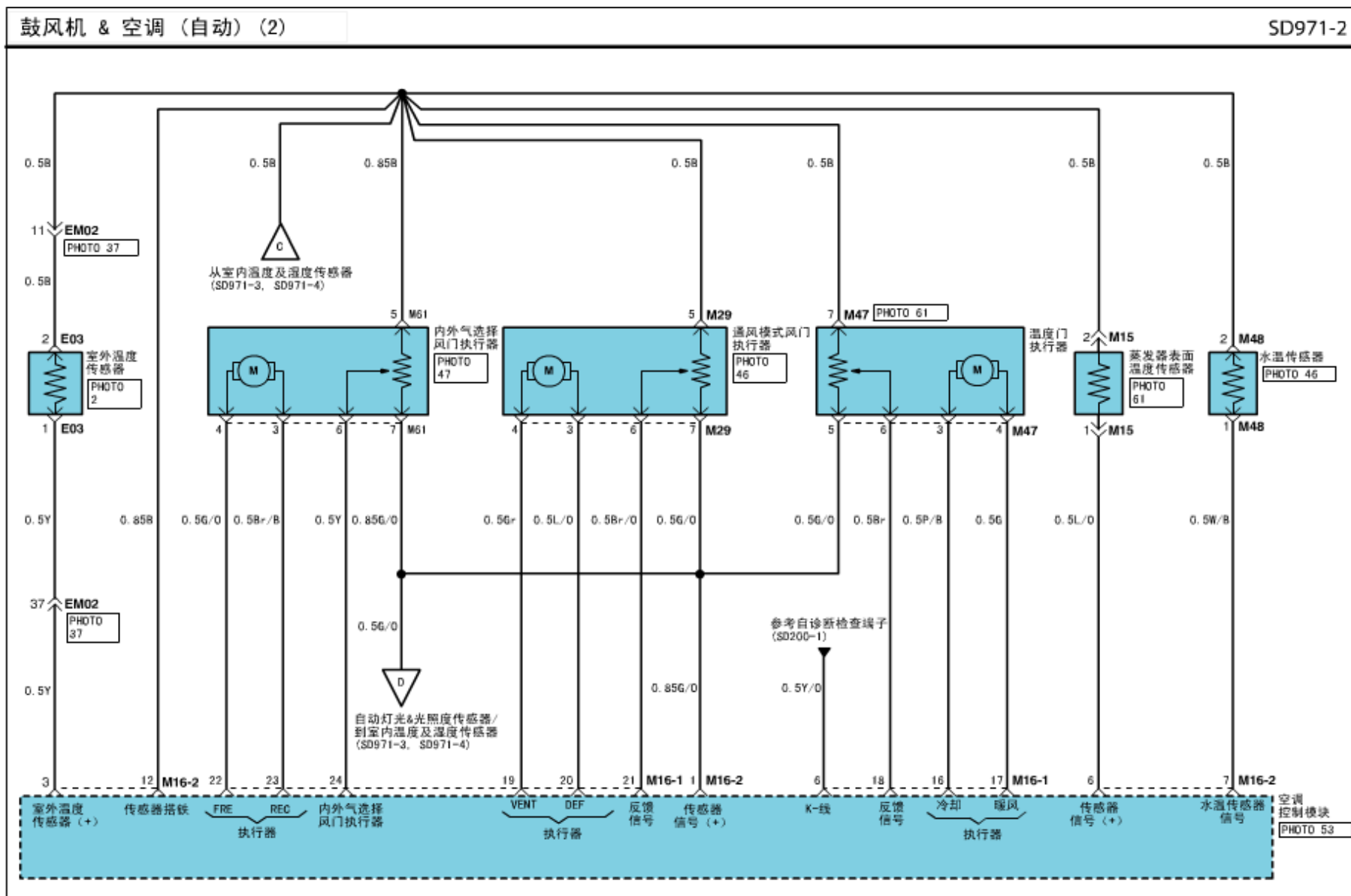

鼓风机 & 空调 (自动)

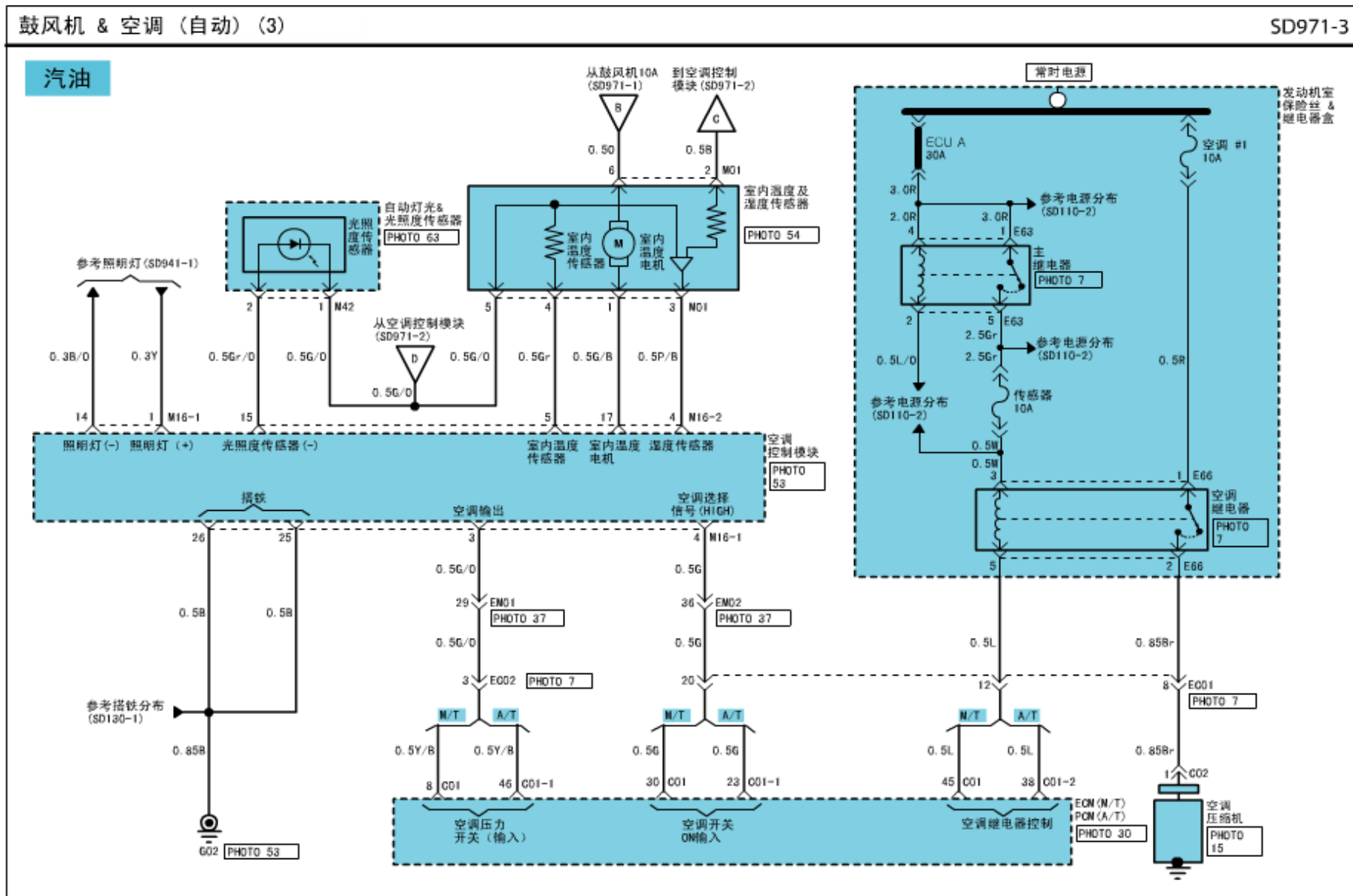

鼓风机 & 空调 (自动)

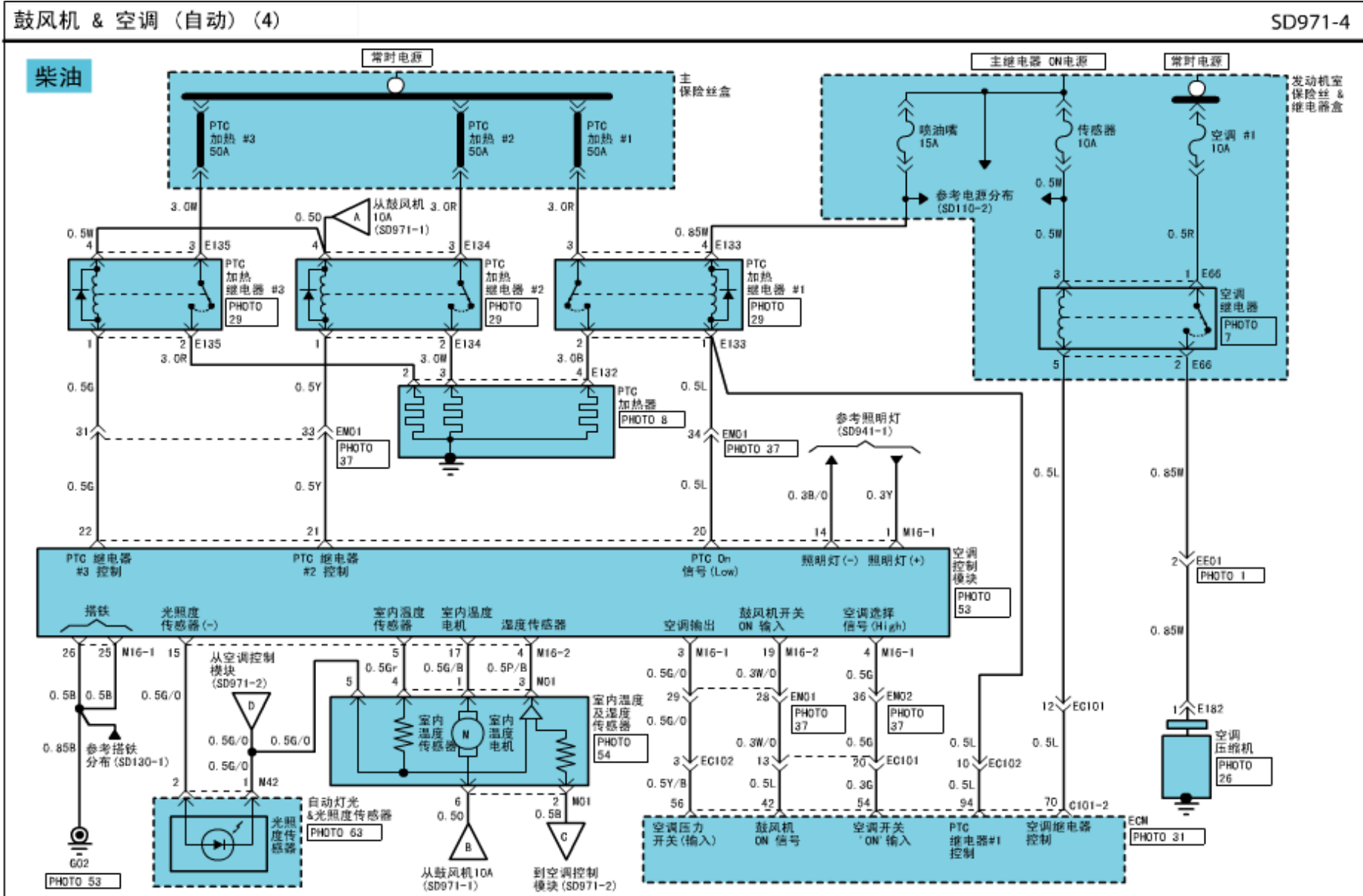



鼓风机 & 空调 (自动)

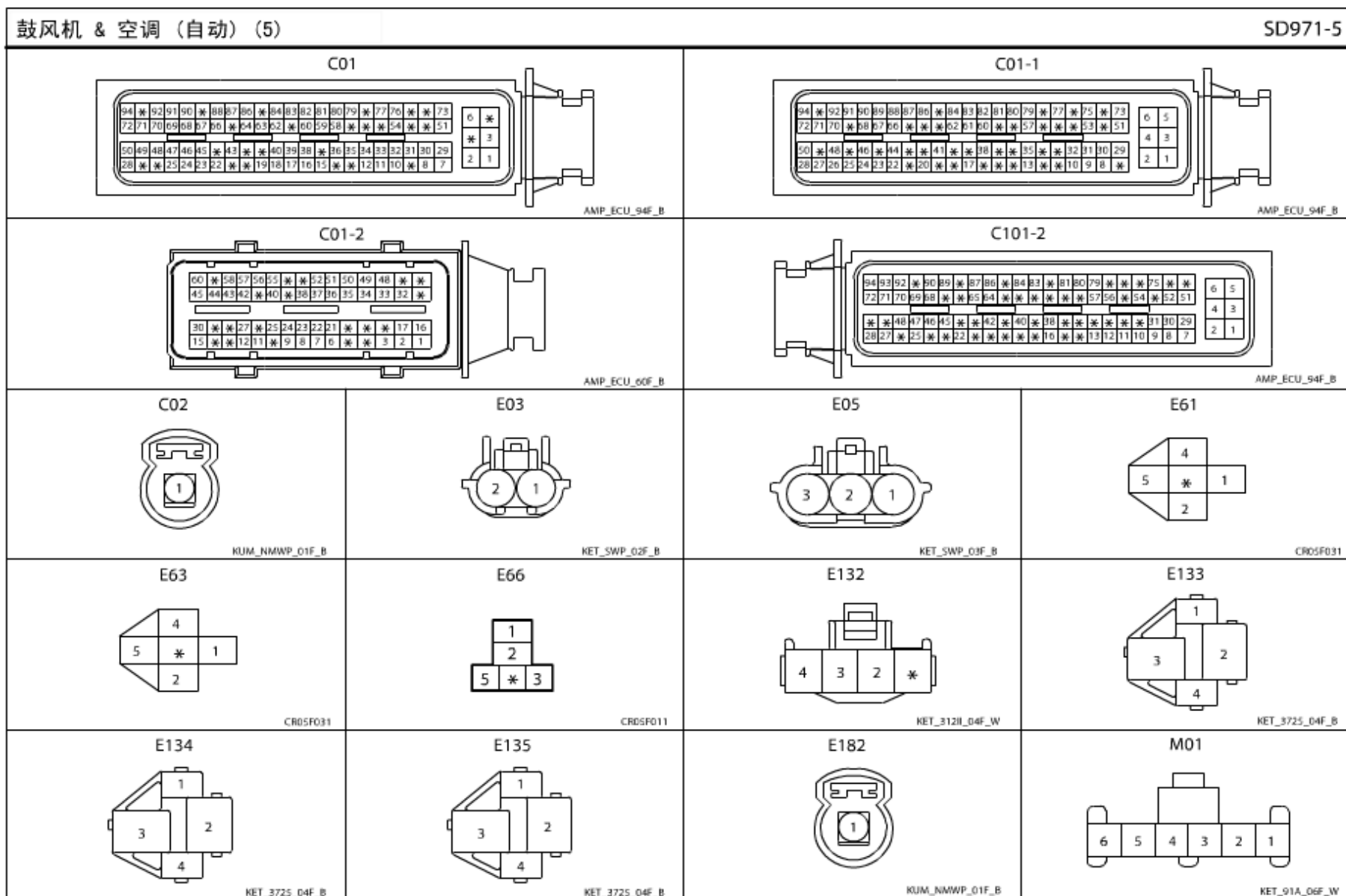

鼓风机 & 空调 (自动)

鼓风机 & 空调 (自动) (6)			SD971-6
<p><b>M05</b></p> <p>KUM_D5D_02F_W</p>	<p><b>M15</b></p> <p>AMP_070_02F_W</p>	<p><b>M16-1</b></p> <p>AMP_0407_26F_W_HD</p>	
<p><b>M16-2</b></p> <p>AMP_0407_22F_W_HD</p>	<p><b>M29</b></p> <p>KUM_CDR_07F_B</p>	<p><b>M30</b></p> <p>KUM_D5D_03F_W</p>	<p><b>M42</b></p> <p>KET_0908_02F_W_L</p>
<p><b>M47</b></p> <p>KUM_CDR_07F_W</p>	<p><b>M48</b></p> <p>AMP_0908_02F_W_SPK</p>	<p><b>M61</b></p> <p>KUM_CDR_07F_W</p>	<p>BLANK</p>